



Solenoid valve 2/2 way N.C. Direct acting - NSF Certified

21JP1R1V12-T0
÷
21JP1R1V23-T0

PRESENTATION:

Direct acting S.V. for interception of fluids compatible with the construction materials.

Minimum operational pressure is not required.

The materials used and the tests carried out ensure maximum reliability and duration.

USE: Vending

PIPES: G 1/8

COIL:

2,5W - Ø 10	
LBA	155°C (class F)
5W - Ø 10	
LBA	155°C (class F)
LBF - LBV	180°C (class H)

COIL HOUSING AND COIL FORMER MATERIAL ARE MADE BY 100% VIRGIN MATERIAL.

Max. allowable pressure (PS) 16 bar

Ambient temperature:

See coils catalogue page for its compatibility.



Gaskets	Temperature		Medium
V=FKM (fluoroelastomer)	- 10°C	+ 140°C	Water, air, steam

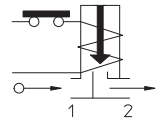
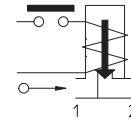
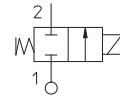

Pipe ISO 228/1	Code	Max viscosity		Ø mm	Kv l/mn	Power watt	Pressure		
		cSt	°E				min bar	M.O.P.D. AC bar DC bar	
G 1/8	21JP1R1V12-T0	12	~ 2	1,2	1	2,5	0	15	3,5
						5			12
	21JP1R1V23-T0	37	~ 5	2,3	2,1	2,5		6	-
						5		15	8



Note

Max torque for fittings 1,5 Nm, coil nut assembly 2 Nm max; armature tube 4 Nm | Evaluate tightening torque for tapered fittings | Use the seal fittings compatible with the material of the body | Available with coil Ex nA | The use of rigid sealings (Ruby or PTFE) usually implies a slight leakage, limited within 2scc/min at the pressure of 1 bar | For application with steam or with PS above the 16 bar, please consult our Technical Service|Available on request and with minimum quantities.

The "ODE " reserves the right to carry out technical and aesthetic modifications without prior notice.

MATERIALS:

Body	PPS
Armature tube	Stainless steel AISI series 300
Fixed core	Stainless steel AISI series 400
Plunger	Stainless steel AISI series 400
Phase displacement ring	Gold plated copper
Spring	Stainless steel AISI series 300
Seal	V=FKM
Orifice	PPS

On request:

Connector	Pg 9 or Pg 11
Connector conformity	ISO 4400

FEATURES:

Electrical conformity	IEC 335
Protection degree	IP 65 EN 60529 (DIN 40050) with coil fitted by connector.

SPARE PARTS:

1. Coil:

See coils list

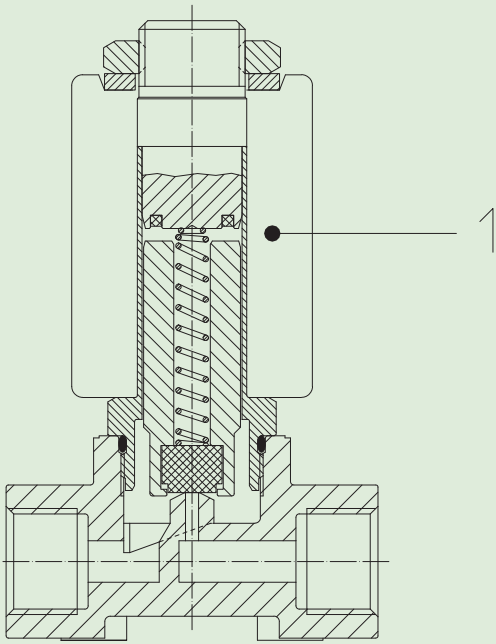

DIMENSIONS:

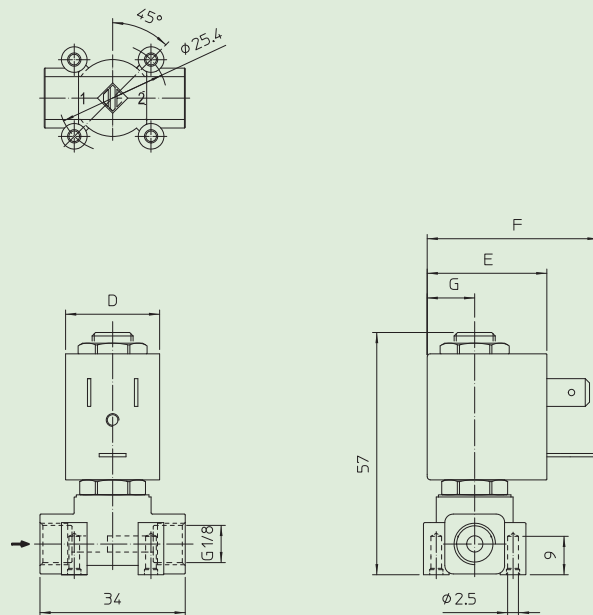

COIL TYPE	POWER ABSORPTION			DIMENSIONS			
	W =	Hold VA ~	Inrush VA ~	D mm	E mm	F mm	G mm
L	2,5	5	7	22	27,5	39,5	11
	5	10	15				