



Solenoid valve 2/2 way N.C. Combined operation

21HF6K0V250

÷

21HF8K0V400

PRESENTATION:

Combined operation S.V. for interception of fluids compatible with the construction materials.

Minimum operational pressure is not required.

The materials used and the tests carried out ensure maximum reliability and duration.

USE: Automation
Heating

PIPE: G 1 - G 1 1/2

COILS:

8W - Ø 13	
BDA - BSA	155°C (class F)
BDV	180°C (class H)
12W - Ø 13	
UDA	155°C (class F)
14W - Ø 13	
GDH - GDV	180°C (class H)

COIL HOUSING AND COIL FORMER MATERIAL ARE MADE BY 100% VIRGIN MATERIAL.

Max. allowable pressure (PS) 16 bar

Ambient temperature:

See coils catalogue page for its compatibility.



Gaskets	Temperature		Medium
	- 10°C	+ 90°C	
B =NBR (nitrile rubber)	- 10°C	+ 90°C	Air, inert gas, water
E =EPDM (ethylene-propylene)	- 10°C	+ 140°C	Water, steam
V =FKM (fluoroelastomer)	- 10°C	+140°C	Mineral oils (2°E), gasoline gas oil

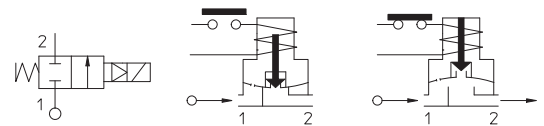

For seals other than FKM replace the letter "V" with the ones corresponding to the other seals. E.I. 21HF6K0**B**250.

Pipe ISO 228/1	Code	Max viscosity		Ø mm	Kv l/mn	Power watt	Pressure		
		cSt	°E				min bar	M.O.P.D.	
								AC bar	DC bar
G 1	21HF6K0V250	12	~ 2	25	140	8	0	16	5
						12			16
						14			-
G 1 1/4	21HF7K0V350	12	~ 2	35	270	8	0	16	-
						12			-
						14			6
G 1 1/2	21HF8K0V400	12	~ 2	40	280	8	0	16	-
						12			-
						14			6



CE Approval

(Pressure Equipment Directive 2014/68/EU)

for S.V. 21HF7÷21HF8

The "ODE" reserves the right to carry out technical and aesthetic modifications without prior notice.

MATERIALS:

Body Brass - UNI EN 12165 CW617N
Armature tube Stainless steel AISI series 300
Fixed core Stainless steel AISI series 400
Plunger Stainless steel AISI series 400
Phase displacement ring Copper - Cu 99,9%
Spring Stainless steel AISI series 300
Seal Standard: V=FKM
 On request: E=EPDM B=NBR
Orifice Brass - UNI EN 12165 CW617N

On request:
Connector Pg 9 o Pg 11
Connector conformity ISO 4400

FEATURES:

Electrical conformity IEC 335
Protection degree IP 65 EN 60529 (DIN 40050)
 with coil fitted by connector.

SPARE PARTS:

- | | |
|--|--|
| <p>1. Coil:
See coils list</p> <p>2. Complete armature tube:
Code R450603</p> <p>3. Gasket O-Ring:
Code R990000/V</p> <p>4. Gasket O-Ring:
G 1 Code R990153/V
G 1 1/4+G 1 1/2 Code R992061/V</p> <p>5. Complete diaphragm with plunger:
G 1 Code R452269/V
G 1 1/4+G 1 1/2 Code R452395/V</p> | <p>6. Gasket O-Ring:
G 1 Code R990002/V</p> |
|--|--|

MAINTENANCE KIT:

- G 1
 KTGHF5K0V20= 4+5+6
 G 1 1/4+G 1 1/2
 KTGHF7K0V35=4+5

DIMENSIONS:

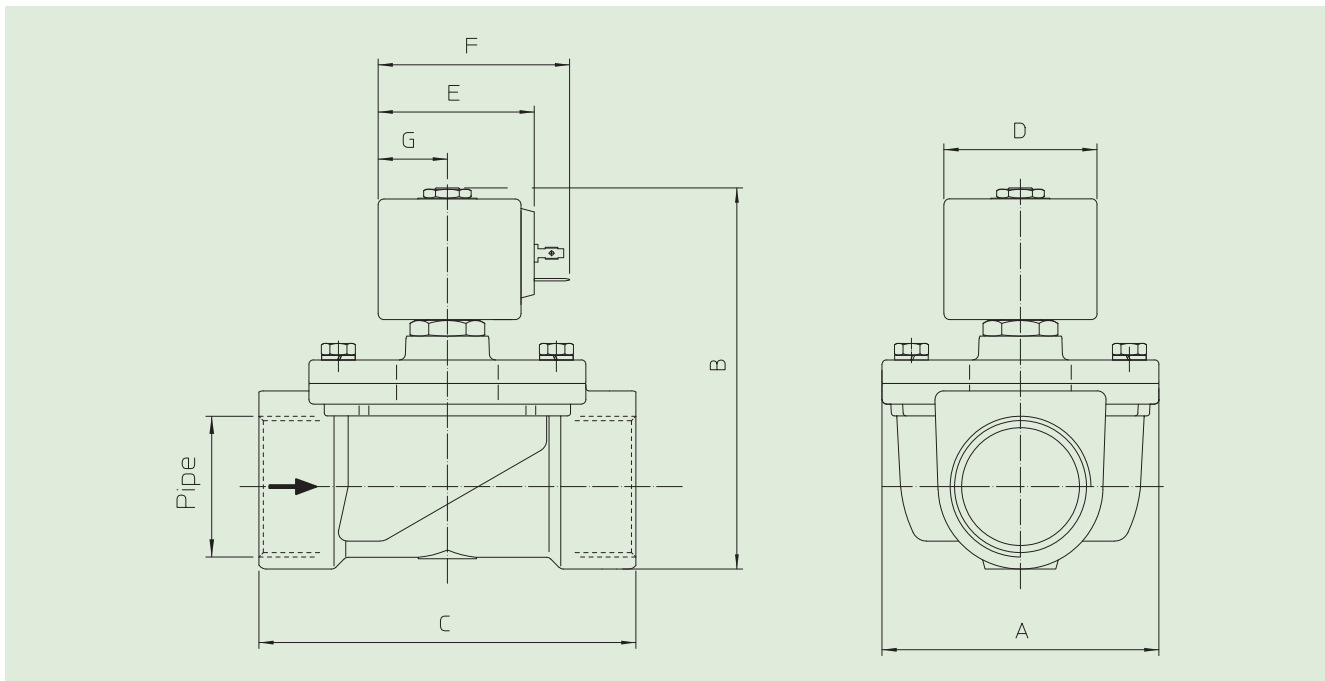

Type	Pipe ISO 228/1	A mm	B mm	C mm
21HF6K0V250	G 1	65	110	104
21HF7K0V350	G 1 1/4	94	130	128
21HF8K0V400	G 1 1/2			

COIL TYPE	POWER ABSORPTION			DIMENSIONS			
	W ==	Hold VA ~	Inrush VA ~	D mm	E mm	F mm	G mm
B	8	14,5	25	30	42	54	21
U	12	23	35	36	48	60	24
G	14	27	43	52	55	67	25